

6 Install Cartridges

Once you have installed the media, the installer will prompt you to install the cartridges.

Open the Top Cover. Click the **Install Cartridges** button to start the cartridge installation process. The Cartridge Carrier will move itself to the center of the print area.

1. Press the Cartridge Cover Release to open the Cartridge Holder.
2. Remove each cartridge from its packaging and slowly remove the tape covering the cartridge's print head.

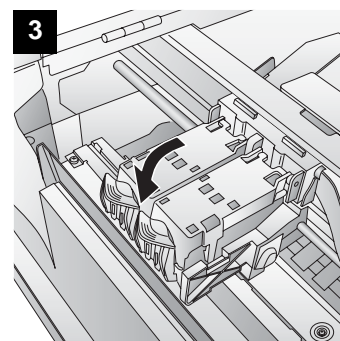
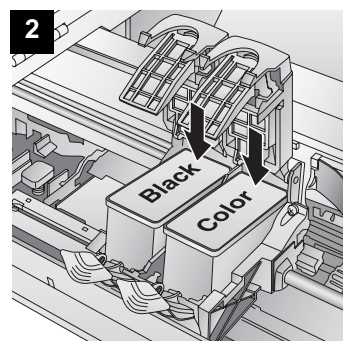
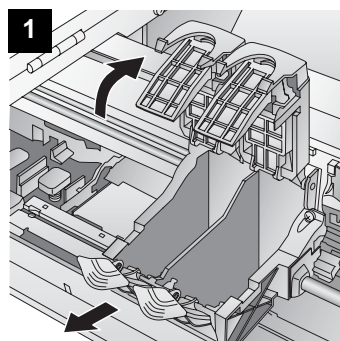

3. Replace/install the cartridge.
4. Push cartridge cover downward until it snaps in place.
5. Close the Top Cover.

Click **Finished Installing Cartridges** to confirm the cartridges have been installed. You will now be prompted to align your cartridges.

Click **Align Cartridges** to start the cartridge alignment. The LX800 will now print and automatically scan a pattern of lines that will align the black cartridge to the color cartridge.

7 Finishing the Install

After the cartridges and the label media have been installed and configured, the installer will complete its process by installing the NiceLabel SE software on your computer. Simply click Next to continue installing, and follow the onscreen instructions to the finish.

Note: For optimal printing speed you MUST reboot the PC after installing the software!

8 Congratulations

Congratulations! Your LX800 is now installed and ready for use. Please refer to Section 3 of the User Manual for a tutorial on using NiceLabel® SE.

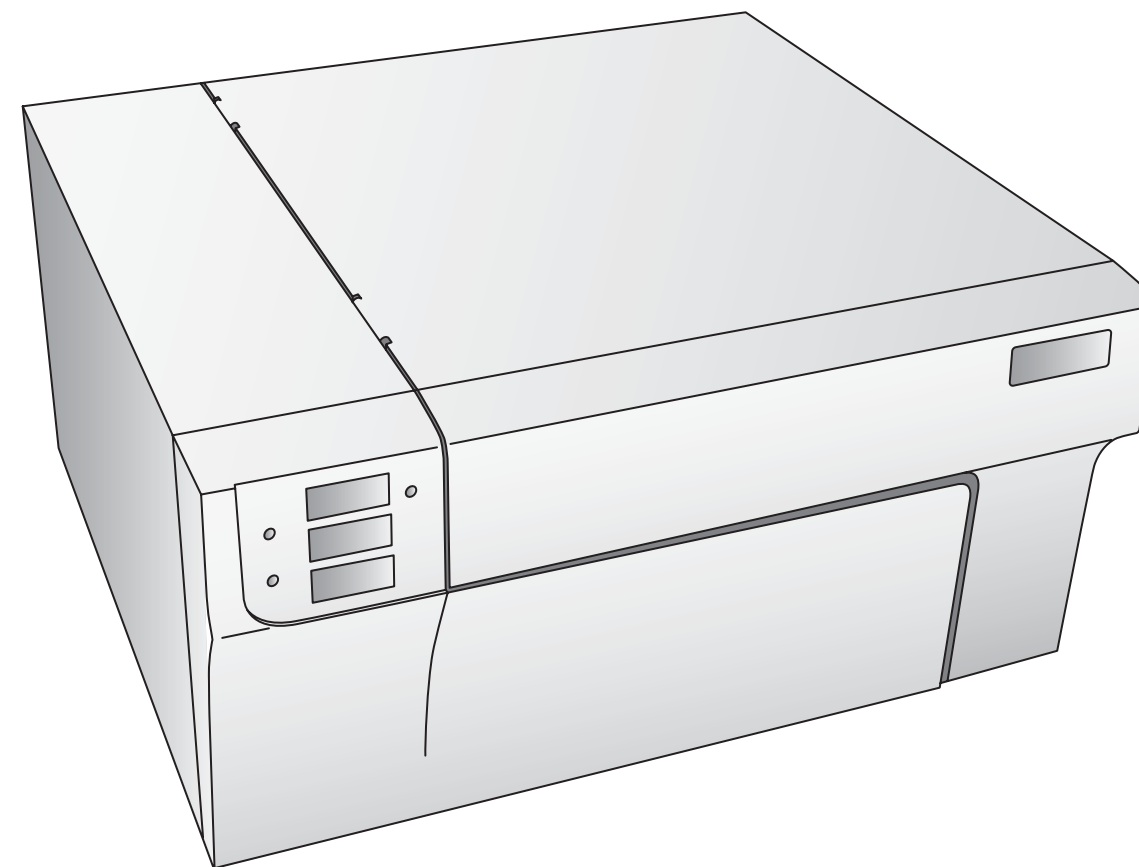

LX 800

COLOR LABEL PRINTER

Quick Start

1 Unpack Your Printer

- Printer
- Power Adapter
- Color Ink Cartridge, Reorder # 53335
- Dye-Based Black Ink Cartridge, Reorder # 53336
- Starter roll of label stock 6" x 4" High-Gloss
- Tear Bar Guard (This is a white plastic shield attached to the Tear Bar for shipping and can be simply pulled from the tear bar to reveal the serrated edge. This guard is recommended for use when using pre-perforated label material.)
- Warranty Statement and Registration Card
- This manual and other printed information
- Separate Power Cord
- Software Installer CD

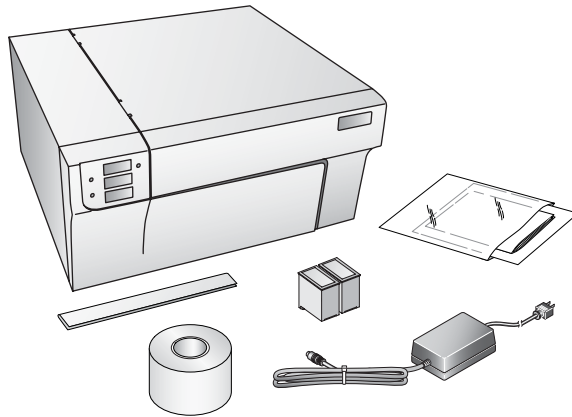

Note For optimal printing speed you must have a PC with the following minimum specifications:

- Pentium IV Processor
- 512 MB of RAM
- 5 GB of Free Hard Drive Space

2 Quick Start Installer

1. Insert the Installation CD into your computer. In a few moments the installer program should launch automatically. If not, perform the following steps:

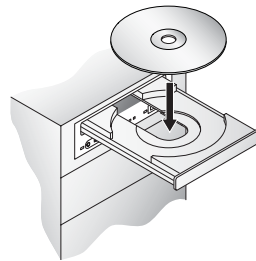

- a. Double click My Computer Icon, then double click the icon of the appropriate CD drive containing the software installer disc.
- b. Double click INSTALL.exe then click the Quick Start Install Button.

2 Quick Start Installer (continued)

2. In the installer application click the Quick Start Install Button. The QuickStart Install will guide you step-by-step through the installation process. As you complete each step, click Next. Steps 3-7 are shown below as well as on the monitor. You may follow either to complete the setup.

3 Apply Power

Turn on the Power Switch.

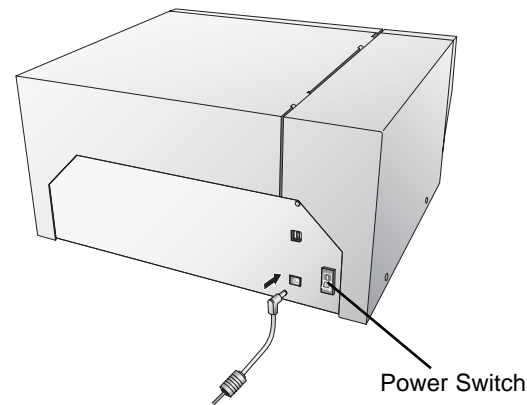

4 Connecting the USB Cable

Plug in the USB Cable

After a few moments Windows will detect the printer and attempt to install the printer driver. Follow the on-screen prompts to install the driver. You will be prompted with a dialog box like the one shown here:



Click "Continue Anyway".

Once installed the "Color Label Printer" icon will appear in the printers folder.

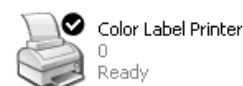

5 Install Label Material

The installer should prompt you to install label material. It is recommended for the first install that you use the starter label roll that ships with your printer.

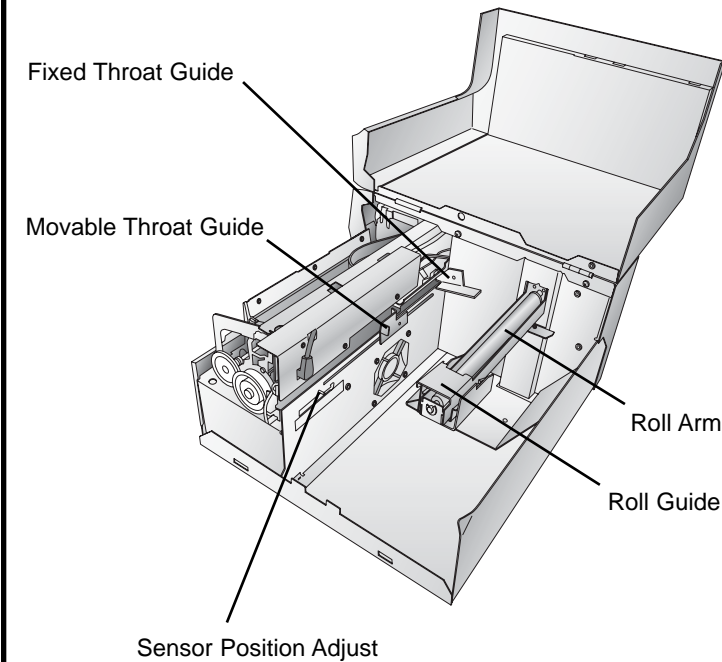

1. Open the Top Cover.
2. Lower the Roll Guide and pull it outward to make room for your label stock.
3. Pull the Movable Throat Guide outward to make room for the label stock.

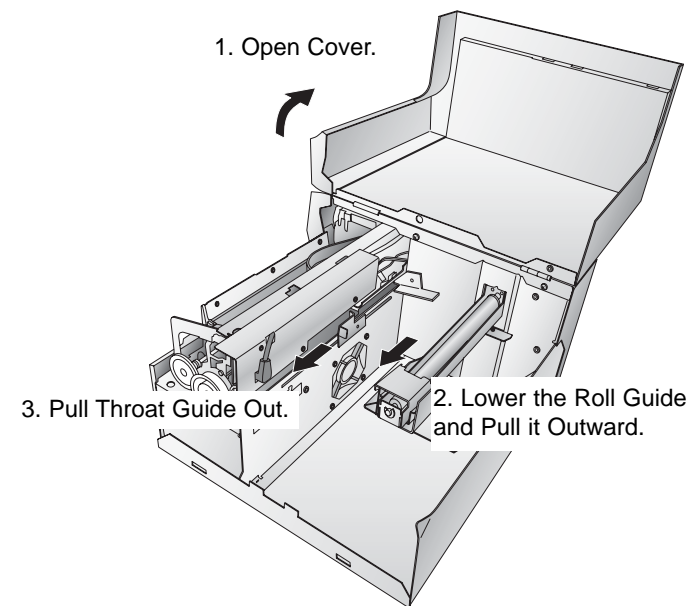

4. Remove any shipping tape from your label stock roll to ensure that it can unroll freely, making certain that no adhesive portion is exposed. It is important to note that any exposed adhesive surface can attach itself to the inner workings of the print mechanism and cause a media jam.
5. Place your roll of label stock on the Roll Arm and push it inward until it touches the stop.
6. Flip up the Roll Guide and slide it inward until it touches the label stock. (The Roll Guide will automatically pull back slightly to the correct position)
7. Place the leading edge of label stock under the "label stock" symbols on the Throat Guides. The label stock should be placed far enough into the throat of the printer to correctly position the Movable Throat Guide but not yet into the printer itself. The label stock should be biased against the Fixed Throat Guide.
8. Slide the Movable Throat Guide inward until it **almost** touches the label stock. There must be slightly more space between the Throat Guides than the width of the label stock. If the label stock is pinched by the guides, poor print quality or even feeding problems could result.

5. Place label stock on Roll Arm.

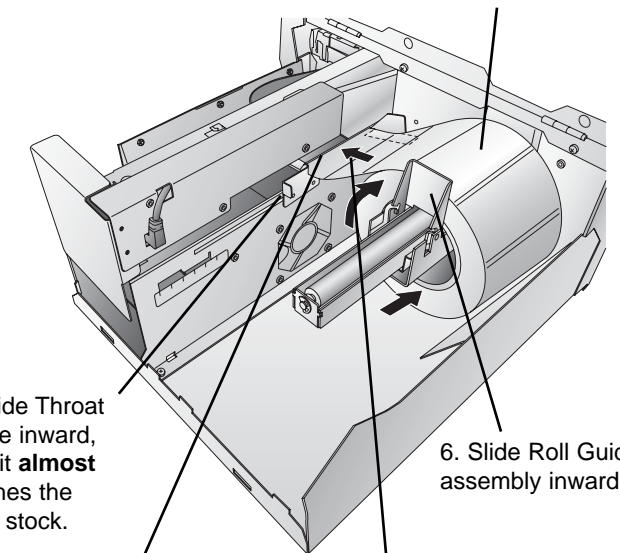

8. Slide Throat Guide inward, until it **almost** touches the label stock.
7. Place the leading edge of the label stock just past the Throat Guides.
9. Feed the label stock further into the printer until it senses the label and automatically feeds it through the printer.
9. Feed the label stock further into the printer until it senses the label and automatically feeds it through the printer.